



Precise height measurement (24 bit) with pressure sensor MS5607

Analog - Digitale
Mikromechanische
Sensorsysteme

The altitude (height) can be accurately measured using a number of different physical methods. These include optical (laser measuring instruments), electronic (microwave detectors), and barometric procedures. The following article outlines how altitude can be measured with a high level of precision using a miniaturized, silicon-based pressure sensor, the MS5607.

The term "atmospheric pressure" describes the pressure generated by the weight of the air that surrounds the Earth. As air is a compressible medium, the atmospheric environment must be denser at its base and the column of air thus heavier than vice versa. The pressure of air thus decreases with rising altitude from its zero point (sea level) at 1013 mbar. Measured from sea level, atmospheric pressure changes at approximately 1 mbar/8 m. This is only an approximation as there is a non-linear correlation between atmospheric pressure and altitude due to the compressibility of air. At the summit of Mount Everest, for example, 8848 m above sea level, the atmospheric pressure is thus 310 mbar.

The next section explains that if the barometric pressure is known, the functional correlation between height and atmospheric pressure can be used to determine altitude.

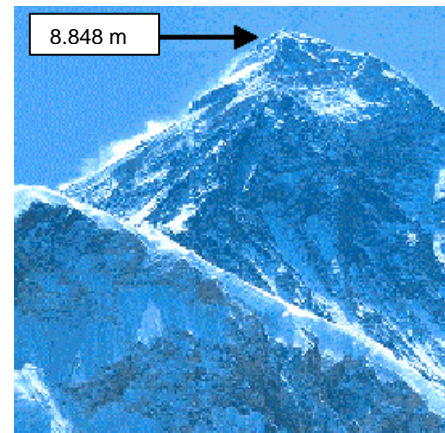

Figure 1: Summit of Mount Everest

The principle of altimetry

The classic barometric formula the children learn at school specifically applies to the case that temperature T is the same whatever the height, i.e. that the atmosphere is isothermal:

$$p(h_1) = p(h_0) e^{-\frac{Mg}{RT} \Delta h} \quad (1)$$

- R = universal gas constant ($8.314 \text{ JK}^{-1} \text{ mol}^{-1}$)
- M = mean molar mass of the atmospheric gases ($0.02896 \text{ kgmol}^{-1}$)
- g = acceleration due to gravity; $g = 9.80620 \text{ m/s}^2$ at the 45th degree of latitude
- T = absolute temperature (273 K)
- $\Delta h = h_1 - h_0$

As a rule, temperature varies with height, however. Adopting a linear approach, whose validity is limited to the troposphere, the following applies for temperature $T(h)$:

$$T(h) = T(h_0) - a \cdot (h_1 - h_0) \quad (2)$$

The barometric formula is thus written as:

$$p(h_1) = p(h_0) \left(1 - \frac{a \Delta h}{T(h_0)} \right)^{\frac{Mg}{Ra}} \quad (3)$$



Precise height measurement (24 bit) with pressure sensor module MS5607

Analog - Digitale
Mikromechanische
Sensorsysteme

Measurements of the temperature profile in the atmosphere show that the linear approach is a good approximation in normal weather conditions, where an average value of 0.65 K/100 m is assumed for a .

R is constant and M and g are assumed to be constants which is justified within the scope of the formula and only leads to minor inaccuracies.

Theoretically, the functional correlation between atmospheric pressure and height (see *Figure 2*) allows us to use an absolute pressure sensor as an altimeter. We should mention, however, that the pressure sensor must be calibrated with a sufficient degree of accuracy within the expected range of measurement. This means that the output signal of the sensor must be proportional to the change in atmospheric pressure and the offset and full-scale signal must be fixed.

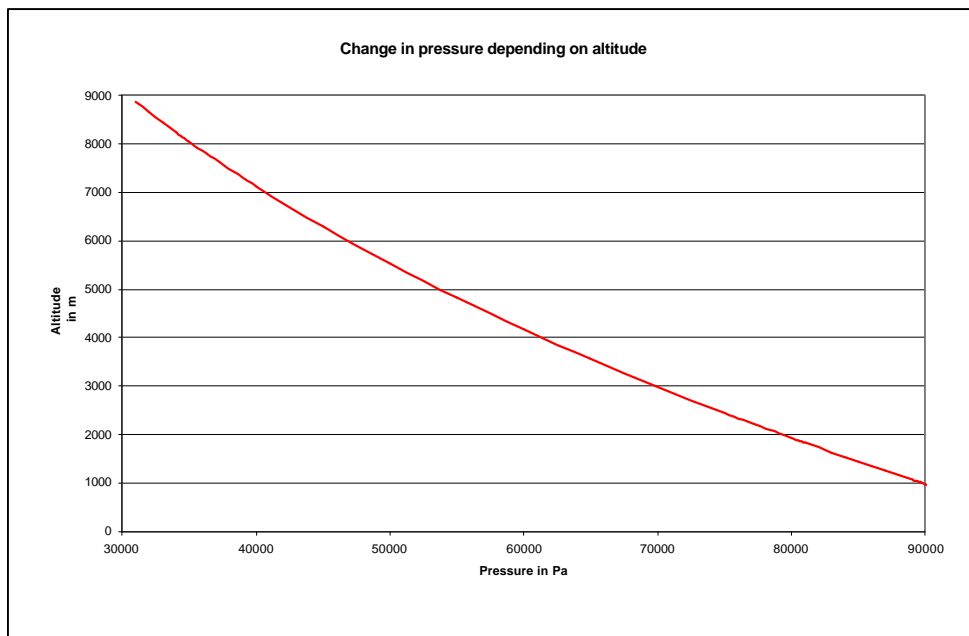

Figure 2: Change in pressure depending on altitude

Practical measurement

If an absolute pressure sensor is used to measure the atmospheric pressure at a required point, we must know that this is always a superimposition of the altitude-dependent and barometric pressure (meteorological conditions). This means that we always measure two different effects when recording atmospheric pressure. This must be taken into account when calculating the altitude.

There are various methods used in the practical determination of altitude, depending on the given conditions.



Precise height measurement (24 bit) with pressure sensor module MS5607

Analog - Digitale
Mikromechanische
Sensorsysteme

A. Height h_0 is known at the initial point of the altitude measurement

At point h_0 whose geographical height is known, we determine the existing pressure $p(h_0)$ and the temperature $T(h_0)$. These are entered in equation (3) together with h_0 . Following the ascent, pressure $p(h_1)$ is measured at point h_1 and this value is then also applied to equation (3). Height h_1 is determined by solving $?h = h_1 - h_0$.

B. Height h_0 is not known at the initial point of the altitude measurement

In this case, quantity h_0 must first be determined. To this end, we need the barometric pressure under normal conditions (isobar map) and the relevant temperature; these quantities are entered in equation (3) and pressure $p(h_1)$ is measured at the initial point of the altitude measurement. With this information we can calculate the absolute height of the place of measurement in relation to sea level using $?h$, with $h_0 = 0$. This value is then quantity h_0 , used to determine the altitude in example A.

In this method, the accuracy of measurement depends on the stability of the weather (barometric pressure). Should this change during the ascent to h_1 , this alteration must be taken into account in the calculation. Here, in example A value $p(h_0)$ must be monitored by a second synchronized pressure sensor at location h_0 and if necessary be adjusted when calculating h_1 .

We must bear in mind that when estimating the achievable accuracy, the equation used is an approximation formula. Its main requirements are the linear march of temperature (without considering adiabatic changes in temperature, mixtures of air caused by changes in the weather, humidity, etc., and M and g are constant) and stable barometric weather conditions. Regardless of the inaccuracy of the formula, when determining altitude the precision and resolution of the pressure sensors used play a major role.

Pressure sensors as altimeters

Most of the altimeters commercially available that are based on pressure sensors have an instrument range of -100 to 4,000, 5,000 or 9,000 meters with a resolution of several tens of meters (max. 14 bit). They can therefore not be described as being particularly precise. Until now, achieving a better level of resolution was a more costly undertaking.

The overall accuracy is just as important as the resolution and, particularly for use outdoors, the temperature behavior of the measuring instrumentation in the offset and in the span signal.

The major practical factors pertinent to mobile systems are their size and that they have a domestic power supply.

All of these characteristics are combined in the new MS5607 24-bit pressure sensor from MEAS Switzerland S.A. The ultra-miniaturized absolute pressure sensor is based on a piezoresistive pressure sensing element and designed as a digital altimeter for mobile applications. As well as determining pressure, the sensor permits a highly accurate measurement of temperature, also necessary when calculating the altitude using equation (3).

Thanks to its small size and low power consumption, MS5607 is suitable for application in mobile systems, such as personal navigation devices, for example.

The pressure sensor is distributed in Germany by the company AMSYS [1].

Absolute pressure sensor MS5607

MS5607 [2] is based on the most advanced semiconductor technology. The chief component of the absolute pressure sensor is a silicon sensing element that works on the principle of piezoresistance. It has a thin membrane as its pressure-sensitive element that is etched anisotropically from the silicon chip. At suitable points local foreign atoms are implanted in the silicon crystal, creating zones with a changed electrical



Precise height measurement (24 bit) with pressure sensor module MS5607

Analog - Digitale
Mikromechanische
Sensorsysteme

conductivity that have the electrical properties of resistors. When pressure is applied to the sensing element, the thin silicon membrane is deformed. The internal forces generate a reversible change of the molecular structure of the crystal. Particularly in the resistors area there are marked shifts in potential in the crystal structure that lead to a measureable change in electrical value (the piezoresistive effect). These resistors are connected up as a bridge so that a pressure-dependent, electrical voltage is obtained on the impression of current or voltage.

The silicon sensing element is mounted on a PCB and electrically connected to the substrate solder pads by gold wires. This device enables standard SMD equipment to be used with pick-and-place robots and reflow or vapor phase soldering.

Signal evaluation circuitry

Besides the sensing element the device also contains an application-specific integrated circuit (ASIC) which in principle functions as a precision ADC. This ASIC records signals and converts the sensing element's analog signals into 24-bit values for pressure and temperature. The ASIC consists of a multiplexer, a 24-bit sigma/delta A/D converter, an EPROM, and a digital output with an SPI and I²C interface.

Special drive technology (a pulsed multiplexer) enables the sensor to be operated with a very low power consumption. This causes only a negligible rise in temperature in the sensitive sensor, resulting in outstanding stability of the output signals from the sensing element.

The converter measures both the output voltage of the sensing element and also the temperature of the bridge resistor. This signal is used to compensate for the temperature-dependent pressure signal and permits the device to act as an extremely high-resolution thermometer (with a resolution of 0.01°C). By using the bridge resistor for the direct measurement of temperature (with no temperature gradients between the sensing element and temperature sensor), even with large fluctuations in temperature the sensor's method of compensation is highly efficient.

The 24-bit sigma/delta A/D converter has been optimized so that it has good linearity and low noise across the entire supply voltage and temperature range. This enables high-resolution altimeters with a resolution of 20 cm (RMS) to be easily realized without the need for any tricky programming. With multiple averaging a resolution of a few centimeters can even be achieved.

On-chip correction

Together with the SPI or I²C interface, the ASIC offers an interface between the piezoresistive pressure sensing element and an external controller using internal factory calibrated coefficients.

These correction coefficients are stored for this purpose in the internal 128-bit EPROM during manufacture. Deviations from the ideal transfer function, caused by manufacturing tolerances, such as offset shift, variations in sensitivity, non-linearity, and tolerances in the IC, are individually measured under defined pressure and temperature conditions and converted into corrected values.

In operation, this corrected sensor data is automatically read out from the EPROM after a power-on reset. Following this, the non-compensated pressure and temperature are alternately provided at the output in a loop. A simple computation with just one multiplication calculates the corrected pressure value and temperature in the external processor.

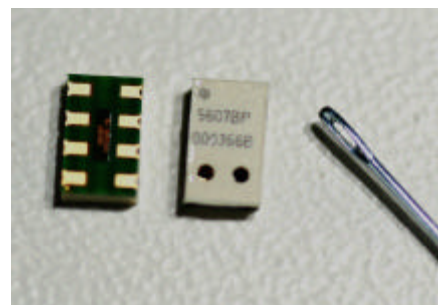

Figure 3: Pressure sensor MS5607



Precise height measurement (24 bit) with pressure sensor module MS5607

Analog - Digitale
Mikromechanische
Sensorsysteme

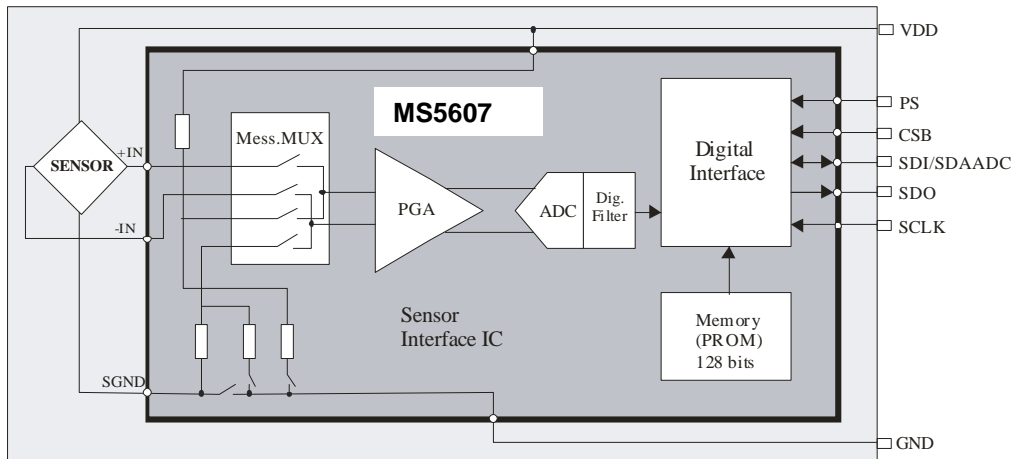

Figure 4: Principle circuitry for MS5607

The fact that the sensor is calibrated and compensated for on the basis of individual internal correction data and with the help of a simple external processor with a three-wire (SPI) or two-wire interface (I²C) gives the user maximum flexibility in his or her system architecture. The sensor is thus of particular interest for those applications that use a processor due to the presence of a master system.

Accuracy and power consumption

The new MS5607 pressure sensor attains a pressure signal resolution of 0.024 mbar within a range of 10 to 1,200 mbar and an overall measurement accuracy of 0.2% FS (equivalent to ± 2.5 mbar between -20 and +85°C). As well as determining pressure, the sensor module can also measure temperature at a resolution of 0.01°C.

Using MS5607 as an altimeter in a digital watch is an extremely good demonstration of just what the pressure sensor can do. At a pressure measurement per second the average power consumption is 0.9 μ A. In stand-by mode 0.02 μ A of current are used. Even with a very small CR1215 (3 V/36 mAh) lithium cell, the battery will last for several years.

Dimensions

The entire pressure sensor is supplied as a QFN package (5.0 x 3.0 x 1.6 mm³) and is thus of a suitable size even for watches. The particular advantage of the new sensor module is that no external components are required.

Conclusion

Modern silicon pressure sensors have almost completely displaced the traditional mechanical barometric cell. However, it is claimed that these new micromechanical sensing elements can only be used for precise measurement at considerable cost, as the nature of their materials makes them inaccurate. Combining modern microtechnology (MEMS) with integrated electronic signal conditioning (ASIC) demonstrates, however, that miniaturization and the demand for precision are in fact extremely compatible. This has been illustrated in the above article by the example of barometric pressure sensor ME5607-B used as an altimeter.

The height of Mount Everest was most recently measured in May 2005 by an expedition from China. The altitude of the summit was recorded as being 8,844.43 meters, with an inaccuracy of ± 2 centimeters. Radar



Precise height measurement (24 bit) with pressure sensor module MS5607

Analog - Digitale
Mikromechanische
Sensorsysteme

detectors, laser measuring instruments, and a satellite positioning system were used. Using the new MS5607 and a more accurate barometric formula, in theory the altitude could also have been calculated to within ± 20 cm.

Further information

- [1] Detailed information on AMSYS pressure sensors: <http://www.amsys.de>
- [2] MS5607 datasheet: <http://www.amsys.de/products/ms5607.htm>
- [3] Products from MEAS Switzerland S.A.: <http://www.intersema.ch>

Contact

AMSYS GmbH & Co. KG
An der Fahrt 13, D – 55124 Mainz
Internet: <http://www.amsys.de>

Phone: +49 (6131) 469 875 – 0
Fax: +49 (6131) 469 875 – 66
Email: info@amsys.de