

AMS 5812

Amplified pressure sensor with an analog and I²C output



Analog - Digitale
Mikromechanische
Sensorsysteme

GENERAL DESCRIPTION

AMS 5812 pressure sensors are a series of high-precision OEM sensors with an analog 0.5 – 4.5 V voltage output and a digital I²C-interface.

AMS 5812 is calibrated and compensated for across a wide temperature range of -25 to +85°C for industrial applications. The device comes as a dual in-line package (DIP) for assembly on printed circuit boards (PCBs) and is fully operational without the need for any additional components. The electrical connection is made via the DIP solder pins; pressure is connected via two vertical metal tubes.

The pressure sensors combine micromachined, high quality piezoresistive measuring cells with a modern, signal conditioning mixed-signal ASIC on a ceramic substrate. This enables high precision measurements and excellent drift and long-term stability of the AMS 5812 series. The complex precision calibration process guarantees optimum temperature compensation.

The sensors in the AMS 5812 series are available for various applications and pressure ranges:

differential (relative) devices in pressure ranges from 0 – 0.075 PSI up to 0 – 100 PSI, an absolute (and barometric) pressure variant for 0 – 15 PSI and bidirectional differential devices in different pressure ranges from

-0.075 /+ 0.075 PSI up to -15/ +15 PSI. Pressure ranges in mbar and bar are available on request.

For all AMS 5812 devices, the analog voltage output is ratiometric to a supply voltage of 5V.

AMSYS GmbH & Co. KG
An der Fahrt 13
55124 Mainz

Tel.: +49 (0)6131-469875 - 0
Fax: +49 (0)6131-469875 - 66
Internet: www.amsys.de
E-Mail: info@amsys.de

FEATURES

- **Amplified, calibrated and temperature compensated pressure sensor**
- **Ratiometric analog voltage output of 0.5 – 4.5V**
- **Digital output for pressure and temperature via I²C interface**
- **High accuracy at RT**
- **Small overall error within a temperature range of -25 ... 85°C**
- **Differential/relative, bidirectional and absolute (barometric) versions**
- **Small DIP package**
- **Ready to use**
- **RoHS compliant**

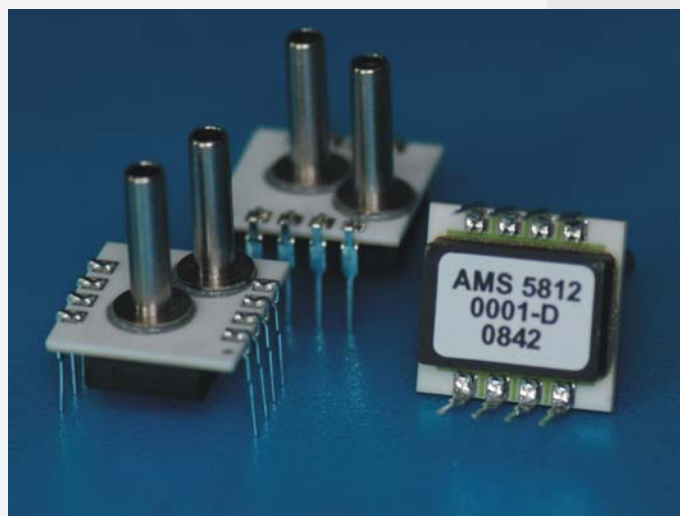

AMS 5812

Amplified pressure sensor with an analog and I²C output

TYPICAL APPLICATIONS

- Static and dynamic pressure measurement
- Barometric pressure measurement
- Vacuum monitoring
- Fluid level measurement
- Gas flow
- Medical instrumentation
- Heating, Ventilation and Air Conditioning (HVAC)

PRESSURE RANGES

Sensor type (code)	Pressure type	Pressure range in PSI	Burst pressure in PSI	Pressure range in mbar	Burst pressure in bar
Ultra low pressure					
AMS 5812-0000-D	differential / relative	0...0.075	72	0...5.17	5
AMS 5812-0001-D	differential / relative	0 ... 0.15	72	0 ..10.34	5
AMS 5812-0000-D-B	bidirectional differential	-0.075 / +0.075	72	-5.17 / +5.17	5
AMS 5812-0001-D-B	bidirectional differential	-0.15 / +0.15	72	-10.34 / +10.34	5
Low pressure					
AMS 5812-0003-D	differential / relative	0 ... 0.3	72	0 ... 20.68	5
AMS 5812-0008-D	differential / relative	0 ... 0.8	72	0 ... 55.16	5
AMS 5812-0015-D	differential / relative	0 ... 1.5	72	0 ... 103.4	5
AMS 5812-0003-D-B	bidirectional differential	-0.3 / +0.3	72	-20.68 / +20.68	5
AMS 5812-0008-D-B	bidirectional differential	-0.8 / +0.8	72	-55.16 / +55.16	5
AMS 5812-0015-D-B	bidirectional differential	-1.5 / +1.5	72	-103.4 / +103.4	5
Standard pressure					
AMS 5812-0030-D	differential / relative	0 ... 3	72	0 ... 206.8	5
AMS 5812-0050-D	differential / relative	0 ... 5	72	0 ... 344.7	5
AMS 5812-0150-D	differential / relative	0 ... 15	72	0 ... 1034	5
AMS 5812-0300-D	differential / relative	0 ... 30	225	0 ... 2068	15.5
AMS 5812-0600-D	differential / relative	0 ... 60	225	0 ... 4137	15.5
AMS 5812-1000-D	differential / relative	0 ... 100	225	0 ... 6895	15.5
AMS 5812-0030-D-B	bidirectional differential	-3 / +3	72	-206.8 / +206.8	5
AMS 5812-0050-D-B	bidirectional differential	-5 / +5	72	-344.7 / +344.7	5
AMS 5812-0150-D-B	bidirectional differential	-15 / +15	72	-1034 / +1034	5
AMS 5812-0150-A	absolute	0 ... 15	72	0 ... 1034	5
AMS 5812-0150-B	barometric	11 ... 17.5	72	758.4 ... 1206	5

Table 1: AMS 5812 standard pressure ranges (other ranges on request)

AMS 5812

Amplified pressure sensor with an analog and I²C output

BOUNDARY CONDITIONS

Parameter	Minimum	Typical	Maximum	Units
Maximum supply voltage: V_S (max)			6.5	V
Operating temperature: T_{op}	-25		85	°C
Storage temperature: T_{amb}	-40		125	°C

SPECIFICATIONS

All parameters apply to $V_S = 5.0V$ and $T_{op} = 25^\circ C$, unless otherwise stated.

Parameter	Minimum	Typical	Maximum	Units
Pressure ranges for different sensors ¹⁾				
Ultra low pressure sensors (differential/relative)	0 ... 0.075		0 ... 1.5	PSI
Ultra low pressure sensors (bidirectional differential)	-0.075 / +0.15		-1.5 / +1.5	PSI
Low pressure sensors (differential/relative)	0...03		1.5	PSI
Low pressure sensors (differential/relative)	-0.3 / +0.3		-1.5 / +1.5	PSI
Standard pressure sensors (differential/relative)	0 ... 3		0 ... 100	PSI
Standard pressure sensors (bidirectional differential)	-3 / +3		-15 / +15	PSI
Analog output signal (pressure only) ²⁾				
@ specified minimum pressure (see "Pressure range")		0.5		V
@ specified maximum pressure (see "Pressure range")		4.5		V
Full span output (FSO) ³⁾		4		V
without pressure (bidirectional differential)		2.5		V
Digital output signal (pressure) ⁴⁾				
@ specified minimum pressure (see "Pressure range")		3277		counts
@ specified maximum pressure (see "Pressure range")		29491		counts
Full span output (FSO) ³⁾		26214		counts
without pressure (bidirectional differential)		16384		counts
Digital output signal (temperature) ⁵⁾				
@ minimum temperature $T = -25^\circ C$		3277		counts
@ maximum temperature $T = 85^\circ C$		29491		counts
Accuracy ⁶⁾ (pressure measurement) @ $T = 25^\circ C$				
Ultra low pressure sensors (0.075, 0.15 PSI)			±1.5	%FSO
Low pressure sensors (0.3, 0.8, 1.5 PSI)			±1.0	%FSO
Standard pressure sensors			±0.5	%FSO
Total accuracy ⁷⁾ (pressure meas.) @ $T = -25...85^\circ C$				
Ultra low pressure sensors (0.075, 0.15 PSI)			±2.0	%FSO
Low pressure sensors (0.3, 0.8, 1.5 PSI)			±1.5	%FSO
Standard pressure sensors			±1.0	%FSO
Total error for temperature measurement				
All types of AMS 5812 $T = -25...85^\circ C$			±3.0	%FSO
Resolution			0.05	%FSO

AMS 5812

Amplified pressure sensor with an analog and I²C output

Supply voltage (V_S)	4.75	5	5.25	V
Current consumption			5	mA
Resolution A/D converter	14		14	bits
Resolution D/A converter	11		11	bits
Reaction time (10%...90% rise time)		1	2	ms
Load resistance at output R_L	2k			Ω
Capacitive load			50	nF
Ratiometricity error (@ $V_S = 4.75 \dots 5.25V$)			500	ppm
I²C-interface				
Input High Level	90		100	% V_S
Input Low Level	0		10	% V_S
Output Low Level	0		10	% V_S
Load capacitance @ SDA			400	pF
Clock frequency SCL			400	kHz
Pull-up resistor	500			Ω
Pressure changes	10^6			
Compensated temperature range	-25		85	$^{\circ}C$
Weight		3		g
Media compatibility	See "Specification notes" ^{8) 9)}			

Table 2: Specifications

SPECIFICATION NOTES

- 1) See *Table 1*
- 2) The analog output signal (pressure measurement only) is ratiometric to the supply voltage.
- 3) The Full Span Output (FSO) is the algebraic difference between the output signal at the specified minimum pressure and the output signal at the specified maximum pressure (see "Pressure range").
- 4) The digital output pressure signal is not ratiometric to the supply voltage.
- 5) The digital output temperature signal is not ratiometric to the supply voltage. The temperature value is measured at the piezoresistive measuring cell and is the sensor temperature (including self heating).
- 6) Accuracy is defined as the maximum deviation of the measurement value from the ideal characteristic curve at room temperature (RT) in %FSO including the adjustment error (offset and span), nonlinearity, pressure hysteresis and repeatability. Nonlinearity is the measured deviation from the best fit straight line (BFSL) across the entire pressure range. Pressure hysteresis is the maximum deviation of the output value at any pressure within the specified range when this pressure is cycled to and from the minimum or maximum rated pressure. Repeatability is the maximum deviation of the output value at any pressure within the specified range after 10 pressure cycles.
- 7) The total accuracy is defined as the overall error, i.e. the maximum deviation of the measurement value from the ideal characteristic curve in %FSO across the entire temperature range (-25 ... 85 $^{\circ}C$).
- 8) Media compatibility of pressure port 1 (for a description of port 1, see *Figure 5*): clean, dry gases, non-corrosive to silicon, RTV silicone rubber, gold (alkaline or acidic liquids can destroy the sensor).
- 9) Media compatibility of pressure port 2 (for a description of port 2, see *Figure 5*): fluids and gases non-corrosive to silicon, Pyrex, RTV silicone rubber.

AMS 5812

Amplified pressure sensor with an analog and I²C output

FUNCTIONAL DESCRIPTION

The pressure sensors in the AMS 5812 series combine a piezoresistive silicon sensing element with a signal conditioning, mixed-signal CMOS ASIC with full digital correction on a ceramic substrate.

The functional principle of the AMS 5812 sensors is explained in *Figure 1*.

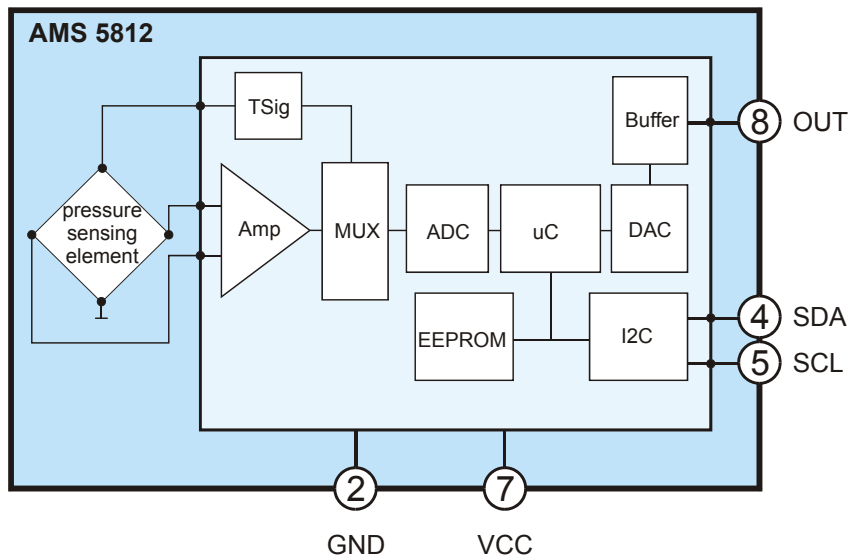

Figure 1: Functional principle

The physical pressure is measured at AMS 5812's piezoresistive pressure sensing element where the pressure is converted into a differential voltage signal which is almost proportional to the pressure. This differential voltage signal is corrected and conditioned by the ASIC in multiple steps.

Firstly, the differential voltage signal from the sensing element is pre-amplified by the amplifier and transmitted by a multiplexer to the A/D converter (ADC). The ADC converts the signal into digital values with a resolution of 14 bits. The digitized signal is corrected and calibrated in the follow-on ASIC microcontroller.

Factory precision calibration of AMS 5812 sets the sensor-specific correction coefficients and stores these in the EEPROM for each sensor. This permits sensor-specific calibration and correction (i.e. temperature compensation and linearization) of the digitized pressure signal. The temperature signal necessary for temperature compensation is also measured at the piezoresistive measuring cell and is transmitted by the multiplexer to the ADC, where it is digitized. The ASIC microcontroller runs a cyclic program which continuously calculates the current standardized and corrected digital pressure values. In addition, a standardized current digital temperature value is calculated. These calculated 15-bit digital values (pressure and temperature values) are written to the ASIC output registers and continuously updated (typically every 0.5 ms).

In order to use the digital signal readout for pressure and temperature, the I2C sensor interface at PIN4 (SDA) and PIN5 (SCL) must be connected to the I2C-bus. The corrected digital values for pressure and temperature at the I2C-interface are not ratiometric to the supply voltage.

To generate the analog output signal the corrected digital pressure value is converted into an analog voltage by an 11-bit D/A converter (DAC). The standardized analog output voltage (0.5...4.5V) at the sensor's PIN8 (OUT) is ratiometric to supply voltage.

AMS 5812

Amplified pressure sensor with an analog and I²C output

INITIAL OPERATION

The sensors are connected up electrically by mounting them on a PCB. The principle circuitry of the AMS 5812 sensor with the analog and the digital output in use is shown in *Figure 2*.

For single use of the analog output it is sufficient to connect up PIN2 (GND), PIN7 (VCC) and PIN8 (OUT).

For operation of the digital output only it is sufficient to connect up PIN2 (GND), PIN7 (VCC) and the I2C-bus lines to PIN4 (SDA) and PIN5 (SCL).

Important: Each I2C-bus communication line has to be connected up to the positive supply voltage VCC (or +5V) using pull-up resistors (4.7 k Ω is recommended). The additional serial resistors are optional (330 Ω is recommended).

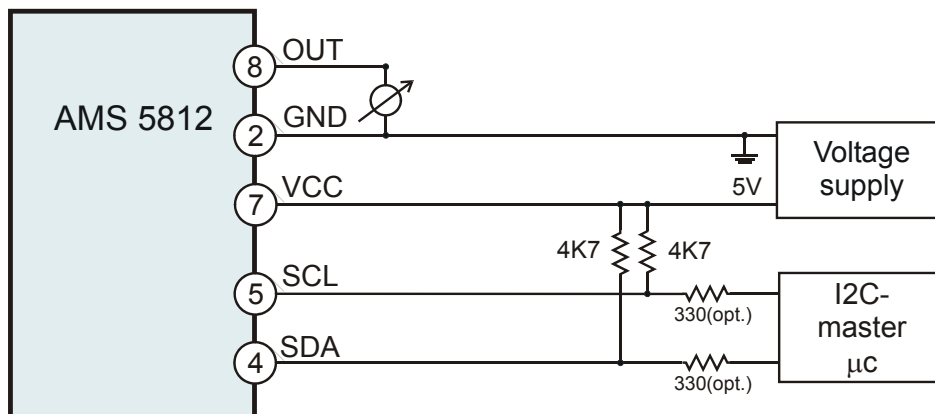

Figure 2: Principle electric circuitry

The sensor pressure connection is made using the two metal pressure ports (hose connectors) on the sensor. Depending on the type of sensor and measuring pressure one or two of the pressure ports are connected up to the measuring media / volume. For the pressures at port 1 and port 2 (see *Figure 5*) the following requirements have to be fulfilled (according to the definition p_1 = pressure at port 1 and p_2 = pressure at port 2):

- | | |
|--|--------------------------------------|
| Differential / relative pressure sensors: | $p_1 > p_2$ |
| Bidirectional differential sensors: | $p_1 > p_2$ or $p_1 < p_2$ possible. |
| Absolute pressure sensors, barometric sensors: | p_1 = measuring pressure. |

The guidelines governing media compatibility must be taken into account here (see "Specification notes", 8 and 9).

AMS 5812

Amplified pressure sensor with an analog and I²C output

I²C-INTERFACE

AMS 5812 pressure sensors have a digital output (I²C-interface). When connected to a bidirectional I²C-bus, the current corrected digital pressure and temperature values can be read out from the output register of the AMS 5812 via the I²C-interface.

Communication via the I²C-bus¹ follows a simple master-slave principle. Data transfer is always initialized by a master (such as a microcontroller, for example), which sends a data request to the sensor; the AMS 5812 sensor – which always operates as slave – then answers.

The I²C-bus requires just two bus lines: a serial data line (SDA) and a serial clock line (SDL). SDA and SDL are bidirectional lines which are connected to the positive supply voltage via pull-up resistors (see *Figure 2*).

I²C communication adheres to a standard I²C communication protocol (given in *Figure 3*).

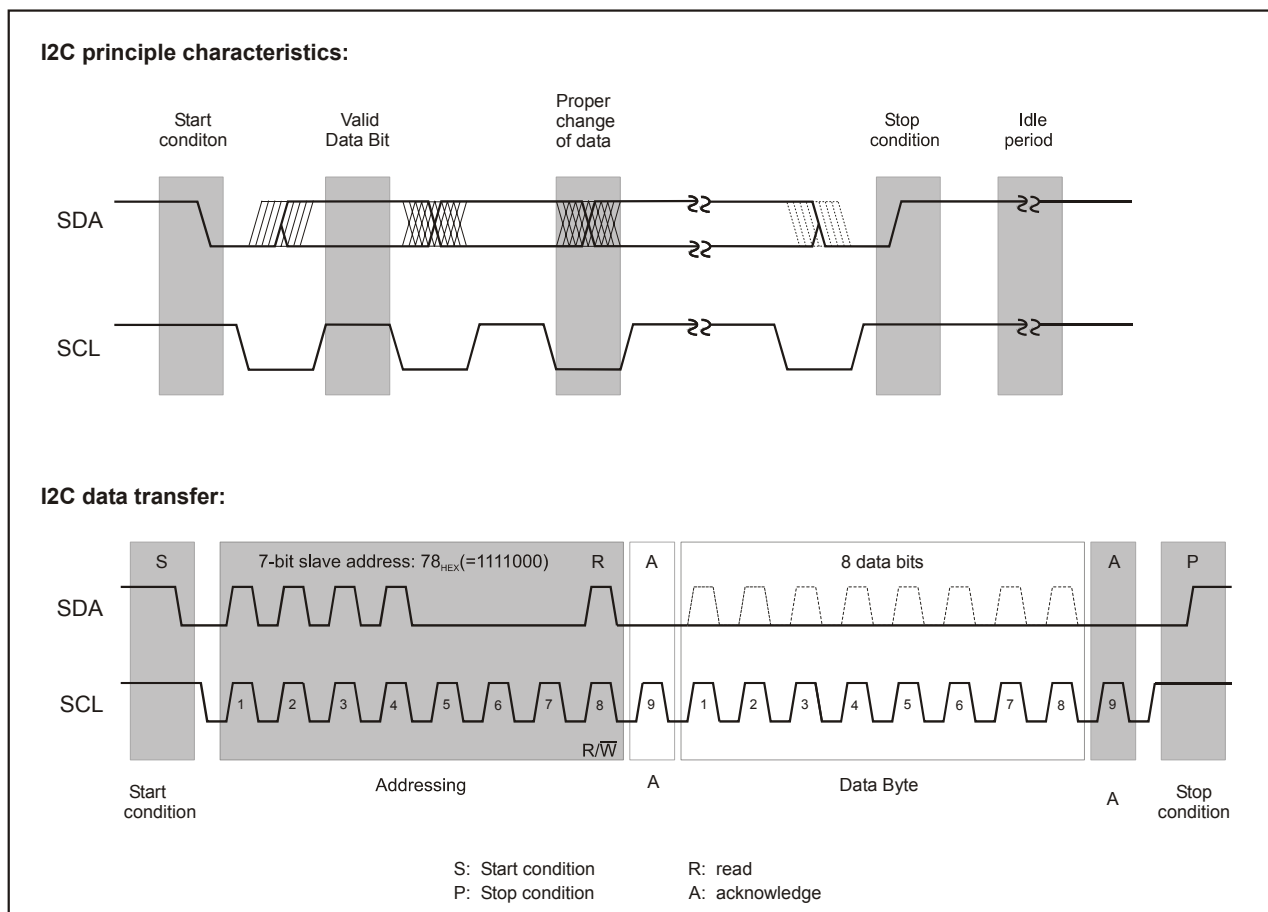

Figure 3: Standard I²C protocol

The I²C communication phases are as follows:

¹ The I²C-bus is a simple, 8-bit-oriented bus which enables communication between different I²C devices. Each device connected to the bus is software addressable using a unique address.

AMS 5812

Amplified pressure sensor with an analog and I²C output

Idle period (bus is free)

When the bus is free, both I2C-bus lines (SDA and SCL) are pulled up to supply voltage level ("high").

Start S (start condition)

Prior to any data transfer on the bus a start condition must be generated. The start condition is always sent by the I2C-master. The start condition is defined as a transition from level "high" to "low" on the SDA line while the level on the SCL line is "high". The digital data readout from the AMS 5812 output register is always initiated by a start condition.

Stop P (stop condition)

The stop condition is always generated by the I2C-master after a data transfer has been completed. The stop condition is defined as a transition from level "low" to "high" on the SDA line while the level on SCL line is "high". The digital data readout from the AMS 5812 output register is always terminated by a stop condition.

Valid data

Data is transmitted in bytes (8 bits), starting with the most significant bit (MSB). One data bit is transmitted with each clock pulse. The transmitted bits are only valid when, following a start condition, the level on the SDA line is constant for as long as the level on SCL line is "high". Changes to the SDA level must be made while the level on SCL line is "low".

Acknowledge A

After a byte has been transmitted the respective receiver (master or slave) has to send an acknowledge (additional acknowledge bit) confirming the correct receipt of the data. To this end the master generates an extra acknowledge-related clock pulse. The receiver sends the acknowledge bit by pulling the level on SDA line down to "low" during the additional clock pulse.

Addressing / Slave address (I2C-address AMS 5812)

After the start condition the master sends an addressing byte (the first byte after the start condition) which determines which slave is selected. The addressing byte contains the individual 7-bit slave address of the selected slave (AMS 5812) and a data direction bit (R/W). An "0" for the R/W bit indicates a transmission from master to slave (W: write; the master wishes to transmit data to the selected slave), a "1" a data request (R: read; the master requests data from the slave).

The pressure sensors in the AMS 5812 series have a standard, factory-programmed 7-bit slave address of 0x78Hex (1111000b)².

² If more than one AMS 5812 should be connected to the same I2C-bus, each pressure sensor requires an individual slave address. On request each AMS 5812 can be ordered with a second individual 7-bit slave address programmed at the factory; 7-bit addressing allows 128 different addresses. With the relevant starter kit customers can also program the second individual slave address for the AMS 5812 themselves. AMS 5812 devices programmed in this way will then answer to both addresses.

AMS 5812

Amplified pressure sensor with an analog and I²C output

DATA READOUT VIA THE I2C-INTERFACE

The (corrected) 15-bit digital values for pressure and temperature are read out from the AMS 5812 output register via the AMS 5812 I2C-interface. The data readout is described in *Figure 4*.

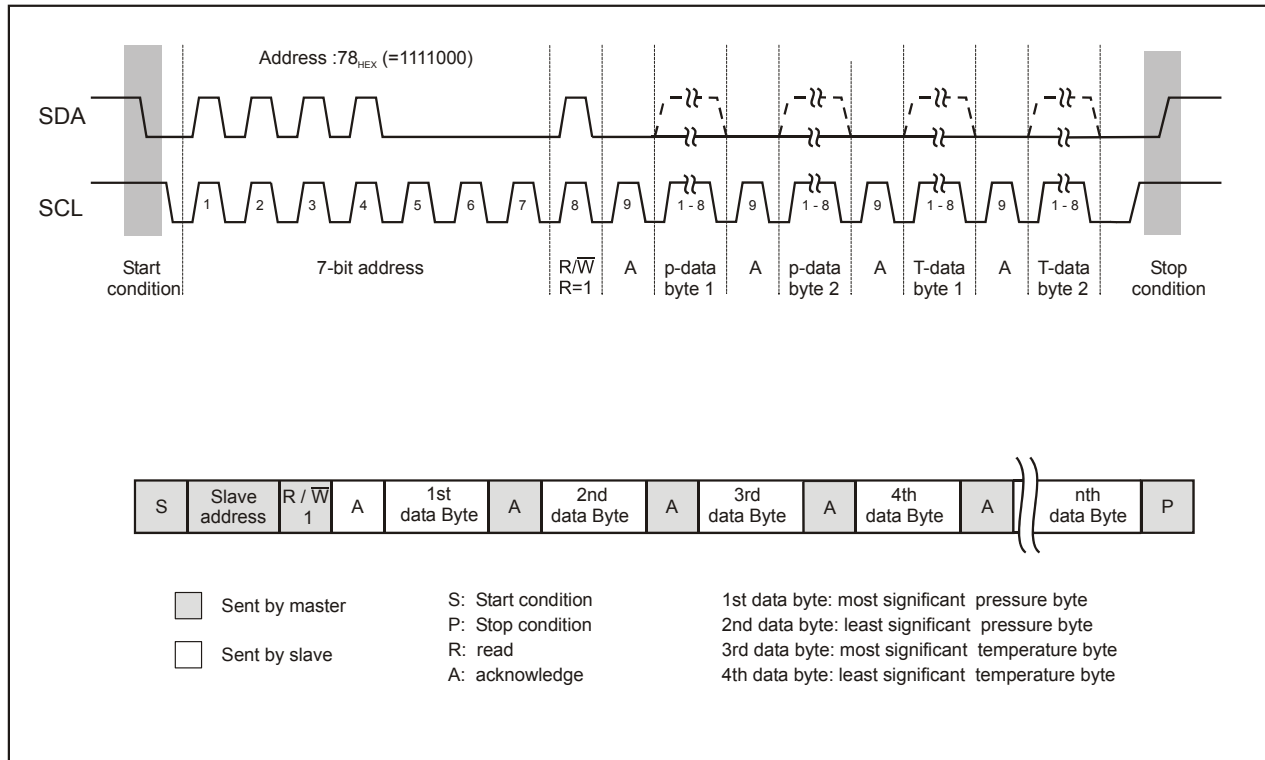

Figure 4: Data readout of the digital pressure and temperature values

Data transfer via the I2C-bus is always initialized by a data request from the I2C-master. For this purpose the I2C-master generates a start condition on the I2C-bus lines. Following the start condition the I2C-master then sends the addressing byte containing the 7-bit slave address of the selected pressure sensor (the AMS 5812 slave address is programmed to 0x78Hex = 1111000b at the factory²) and the data direction bit $R/\overline{W}=1$ which indicates a data request. The selected pressure sensor first answers with an acknowledge bit. The selected sensor then starts the data transfer from the output register. A total of four data bytes are transmitted from the pressure sensor to the I2C-master for the current 15-bit digital pressure value and the 15-bit digital temperature value. The two bytes for the current pressure value are first sent, followed by the two bytes for the current temperature value, always beginning with the most significant byte. On each transferred data byte the I2C-master sends an acknowledge bit confirming the correct receipt of data. If no acknowledge bit is generated by the receiving master, the pressure sensor is set to inactive. The I2C-master shuts down the data transfer by sending a stop condition instead of an acknowledge bit. If the master sends an additional acknowledge bit after the last of the four bytes, pressure sensor AMS 5812 continues to transfer the current pressure and temperature value from the output register, again starting with the most significant pressure byte.

AMS 5812

Amplified pressure sensor with an analog and I²C output

Calculating the current pressure and temperature value from digital 15-bit words

The digital pressure and temperature values are 15-bit words³ (without units) which have to be converted in order to generate the desired information on pressure and temperature in physical units.

The current pressure in PSI (or bar) is calculated from the digital pressure value using the following formulas:

$$p = \frac{\text{Digoutp}(p) - \text{Digoutp}_{\min}}{\text{Sensp}} + p_{\min} \quad \text{with} \quad \text{Sensp} = \frac{\text{Digoutp}_{\max} - \text{Digoutp}_{\min}}{p_{\max} - p_{\min}} \quad (1)$$

Therein p is the current pressure in PSI (or bar), p_{\min} is the specified minimal pressure and p_{\max} is the specified maximum pressure in PSI (or bar); depending on the specified pressure range, $\text{Digoutp}(p)$ is the current digital pressure value in counts, Digoutp_{\min} and Digoutp_{\max} are the digital pressure values at minimum and maximum specified pressure in counts and Sensp is the sensitivity of the pressure sensor in counts/PSI (or counts/bar).

The current sensor temperature in °C is computed from the digital temperature value analogous to the above formulas by replacing the character "p" with a "T."

Example

At the digital output of a pressure sensor of the type AMS 5812-0015-D (0...1.5PSI differential) a current digital pressure value of

$$\text{Digoutp}(p) = 550A_{\text{Hex}} \text{ counts} = 21770_{\text{Dec}} \text{ counts} (= 01010101 \ 00001010_{\text{bin}})$$

and a digital temperature value of

$$\text{DigoutT}(T) = 3A9A_{\text{Hex}} \text{ counts} = 15002_{\text{Dec}} \text{ counts} (= 00111010 \ 10011010_{\text{bin}})$$

is read.

With $p_{\min} = 0$ PSI, $p_{\max} = 1.5$ PSI and $\text{Digoutp}_{\min} = 3277$, $\text{Digoutp}_{\max} = 29491$, the current pressure in PSI is calculated using Formula (1) as:

$$p = \frac{(21770 - 3277) \text{ counts}}{26214/1.5 \text{ counts/PSI}} + 0 \text{ PSI} = 1.058 \text{ PSI}$$

With $T_{\min} = -25$ °C, $T_{\max} = 85$ °C and $\text{DigoutT}_{\min} = 3277$, $\text{DigoutT}_{\max} = 29491$, the current sensor temperature in °C is calculated using Formula (1) as:

$$T = \frac{(15002 - 3277) \text{ counts}}{26214/110 \text{ counts/°C}} + (-25) \text{ °C} = 24.2 \text{ °C}$$

³ Each pressure and temperature value is transmitted as a 15-bit word; the actual resolution of the internal A/D converter, however, is only 14 bits.

AMS 5812

Amplified pressure sensor with an analog and I²C output

DIMENSIONS AND PINOUT

AMS 5812 pressure sensors come in a dual-in-line package (DIP) for assembly on printed circuit boards (PCB).

Figure 5 below gives the pinout and dimensions of the dual-in-line package.

Pinout and pressure connection:

Differential types:

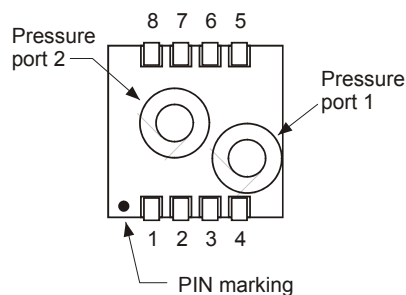

Absolute, barometric types:

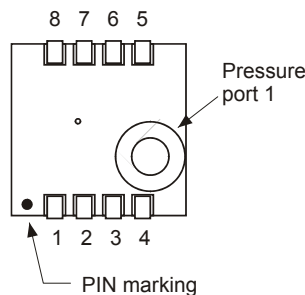

Pin	Description
1	N.C.
2	GND
3	N.C.
4	SDA
5	SCL
6	N.C.
7	VCC
8	OUT

Package dimensions:

Side view :

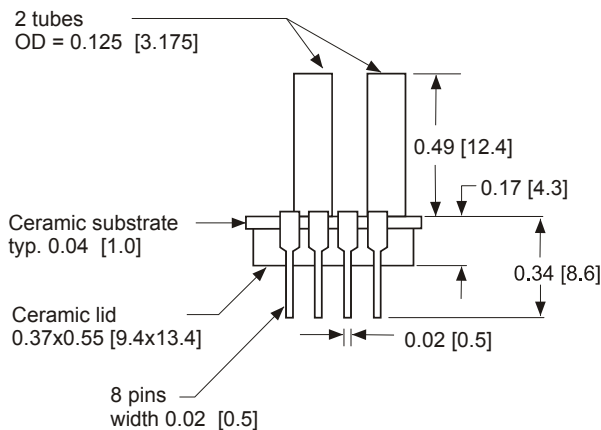

Top view :

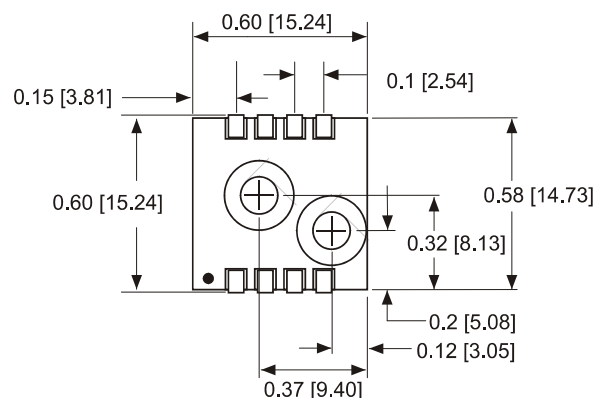

all dimensions in inch [mm]

Figure 5: Dimensions

All sensors in the AMS 5812 series are maintenance free during their lifetime.

AMS 5812

Amplified pressure sensor with an analog and I²C output

INFORMATION FOR ORDERING

Ordering code:

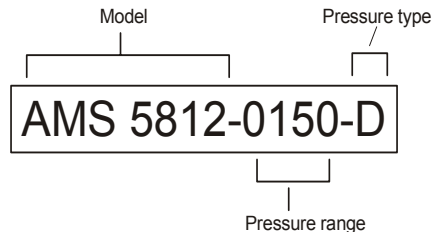

Pressure range:

Pressure range code	PSI	mbar	kPa
0000	0.075	5.17	0.517
0001	0.15	10.34	1.034
0003	0.3	20.68	2.068
0008	0.8	55.16	5.516
0015	1.5	103.4	10.34
0030	3.0	206.8	20.68
0050	5.0	344.7	34.47
0150	15	1034	103.4
0300	30	2068	206.8
0600	60	4137	413.7
1000	100	6895	689.5

Table 3: Pressure ranges

Pressure type:

Pressure type code	Available pressure ranges
D differential / relative (gage)	0...0.075 PSI to 0...100 PSI
D-B bidirectional differential	-0.075/ 0.075 PSI to -100/ 100 PSI
A absolute	0...15 PSI
B barometric (absolute)	11 ... 17.5 PSI

Table 4: Pressure types

ADDITIONAL EQUIPMENT

A starter kit (with software) is available for AMS 5812 sensors. The starter kit permits easy readout of the digital I²C output (pressure and temperature) by a standard PC via the PC's serial RS232 interface. Furthermore, the starter kit can be used to program an individual (second) I²C slave address for the AMS 5812, valid in addition to the I²C slave address programmed at the factory (0x78Hex), and which allows the readout of multiple sensors via the I²C-bus.

AMSYS reserves the right to amend any dimensions, technical data or other information contained herein without prior notification.